



超低阻值厚膜片式固定电阻器

LOW-OHMIC THICK FILM CHIP FIXED RESISTOR

■ 特长 Features

- 体积小、重量轻。 • Miniature and light weight.
- 适应再流焊与波峰焊。 • Suit for reflow and wave flow solder.
- 电性能稳定，可靠性高。 • Stable electrical capability, high reliability.
- 装配成本低，并与自动装贴设备匹配。 • Low assembly cost, suit for automatic SMT equipment.
- 机械强度高、高频特性优越。 • Superior mechanical and frequency characteristics.
- 符合 ROHS 指令要求 • According with RoHS standard



■ 品名构成 Type Designation

例 Example

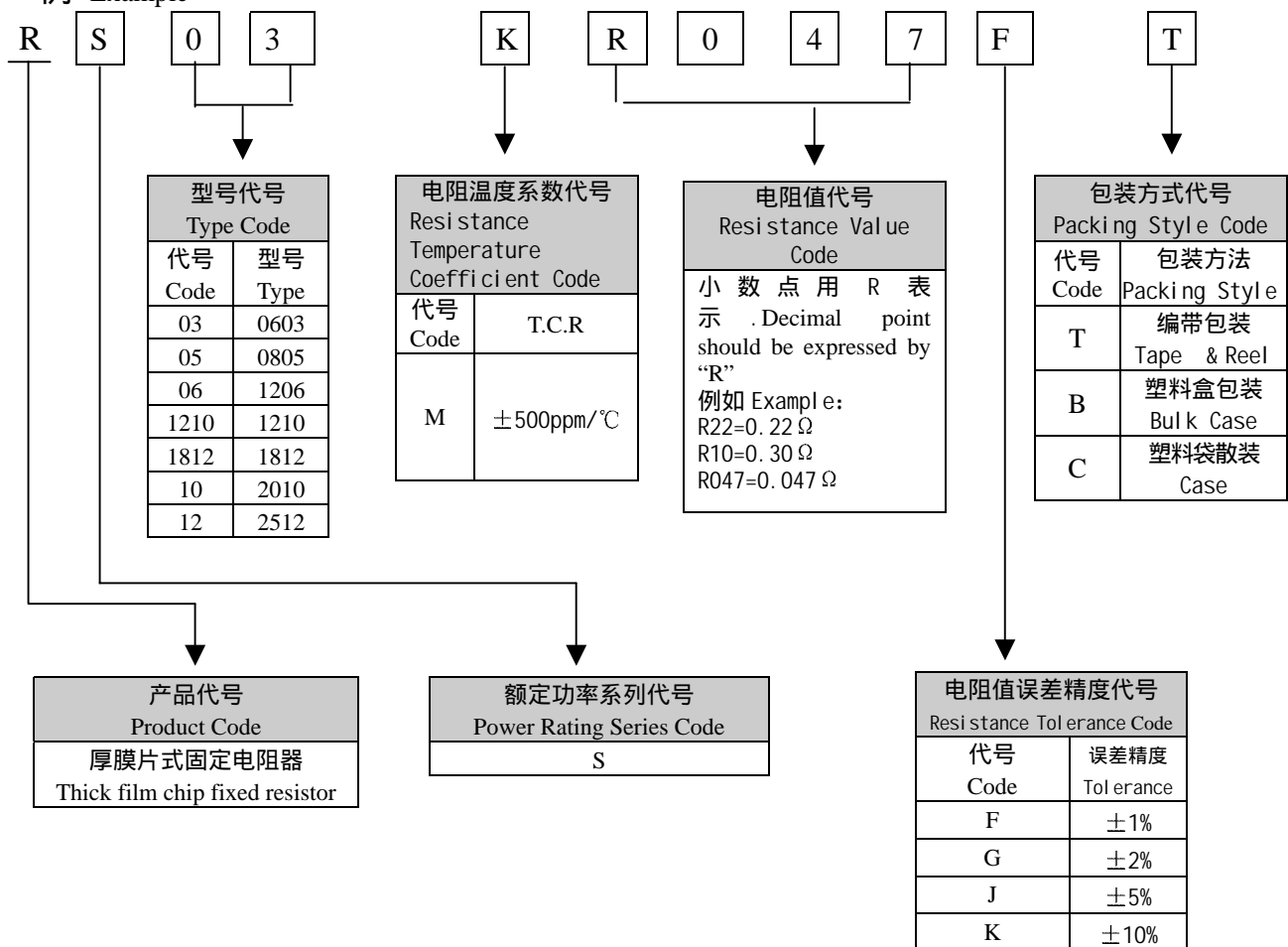



■ 结构及规格尺寸 Construction and dimension

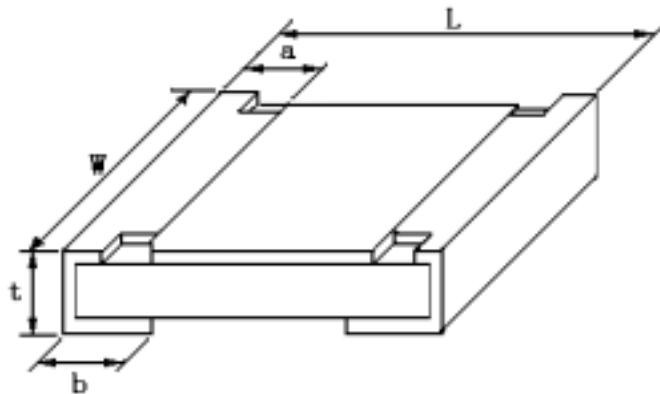
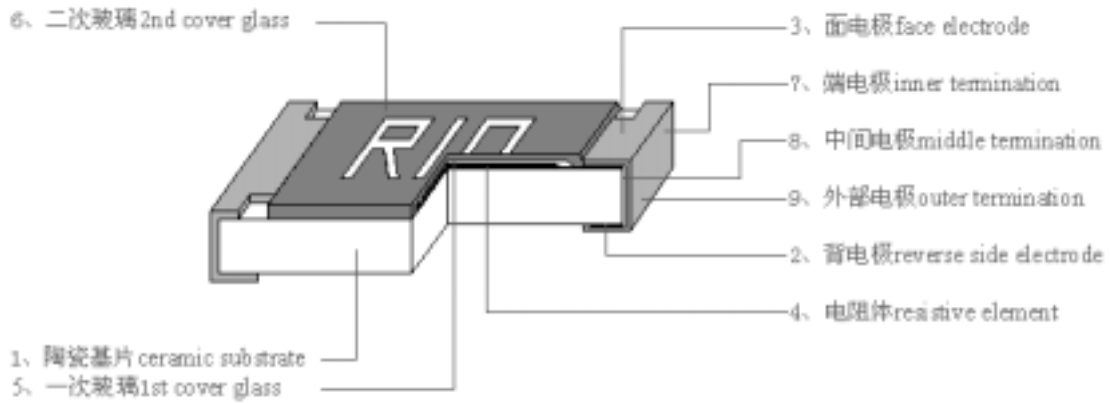

单位 Unit: mm

型号 Type	L	W	t	a	b
0603	1.60±0.15	0.80±0.15	0.40±0.10	0.30±0.20	0.30±0.20
0805	2.00±0.20	1.25±0.15	0.50±0.10	0.40±0.20	0.40±0.20
1206	3.20±0.20	1.60±0.15	0.55±0.10	0.50±0.20	0.50±0.20
1210	3.20±0.20	2.50±0.20	0.55±0.10	0.50±0.20	0.50±0.20
1812	4.50±0.20	3.20±0.20	0.55±0.10	0.50±0.20	0.50±0.20
2010	5.00±0.20	2.50±0.20	0.55±0.10	0.60±0.20	0.60±0.20
2512	6.40±0.20	3.20±0.20	0.55±0.10	0.60±0.20	0.60±0.20



产品外观 Appearance

1. 电阻器表面二次玻璃体保护膜覆盖完好且难以脱落, 表面平整。

The surface of resistor is covered with Protective Coating which hard to fade, and the surface of coating should avoid unevenness.

2. 电阻器引出端电极覆盖均匀、镀层较难脱落, 且平整、无裂痕、针孔、变色。

The terminal part is covered equable, the plating is hard to fade, and should avoid unevenness, flaw, pinhole and discoloration.

3. 电阻器芯片无裂痕、标志可辨。

With a clear mark, the resistor body is crack-free.

4. 0603 规格当 $R < 0.1 \Omega$, 标记用实际的阻值加“V”。如 V47 表示 $47m\Omega$ 。

0603 type: Denotes the actual resistance. for example: V47= $47m\Omega$

■ 参考标准 Reference Standard

GB/T 5729-2003

GB/T 9546-1995

JIS C 5223-1995

JIS C 5201-1998

JIS C 5202-1990

■ 负荷下降曲线 Derating Curve

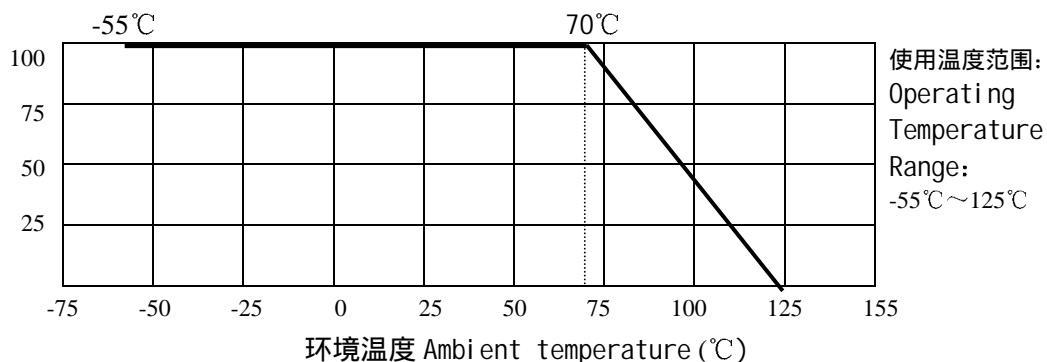

当电阻使用的环境温度超过 70°C 时, 其额定负荷 (额定功率) 按上述曲线下降。

For resistors operated in ambient over 70°C, rated load (power rating) shall be derated in accordance with the above figure.



■ 额定值 Ratings

项目 Item	0603	0805	1206	1210	1812	2010	2512
额定功率 Power Rating	1/10W	1/8W	1/4W	1/3W	1/2W	3/4W	1W
额定电流 Rating Current	0.32~2.24A	0.36~2.50A	0.51~3.54A	0.58~4.08A	0.72~5.00A	0.88~6.12A	1.01~7.07A
电阻温度系数 Resistance Temperature Coefficient	±500ppm/°C						
阻值范围 Resistance Range	0.020 Ω ≤ R < 1 Ω (E-24、E-96 系列)						
阻值误差精度 Resistance Tolerance	±1% ±2% ±5% ±10%						
使用温度范围 Operating Temperature Range	-55°C~+125°C						
额定温度 Rated Temperature	+70°C						

注：额定电压 = $\sqrt{\text{额定功率} \times \text{标称电阻值}}$ 或最大工作电压两者中的较小值。

Note: Rated Voltage = $\sqrt{\text{Power Rating} \times \text{Resistance Value}}$ or Max. Working Voltage, whichever is lower.

■ 特性 Characteristics

项目 Item	标准 Specifications	测试方法 (JIS C 5202 标准) Test Methods (JIS C 5202)
端头强度 Bending Strength	无可见损伤 No mechanical damage $\Delta R \leq \pm (1.0\%R + 0.005 \Omega)$	弯曲速度 (Speed): 1mm/s 弯曲距离 (Bending Distance): 0603、0805、1206、1210: 3mm; 1812、2010、2512: 1mm
电阻温度系数 T.C.R	在规定值内 within specified T.C.R	测定范围: -55°C~+125°C Measure between -55°C~+125°C
温度循环 Temperature Cycling	无可见损伤 No mechanical damage $\Delta R \leq \pm (1.0\%R + 0.005 \Omega)$	-55°C (30 分钟) ~ 常温 (5 分钟) ~ 125°C (30 分钟) 5 个循环 -55°C (30min) ~ normal temperature (5min) ~ 125°C (30min) 5 cycles
短时间过负载 Short Time Overload	无可见损伤 No mechanical damage $\Delta R \leq \pm (2.0\%R + 0.005 \Omega)$	2.5 倍额定电压或最大过负荷电压 (取最小者) 保持 5 秒 2.5 × Rated voltage or Max. Overload Voltage whichever is lower for 5 seconds
稳态湿热 Steady state humidity	无可见损伤 No mechanical damage $\Delta R \leq \pm (3.0\%R + 0.005 \Omega)$	40°C ± 2°C 90%~95%RH 1000 小时 40°C ± 2°C 90%~95%RH 1000h



续上表

70°C耐久性 Load Life	无可见损伤 No mechanical damage $\Delta R \leq \pm (3.0\%R + 0.005 \Omega)$	70°C ± 2°C, 1000 小时, 额定电压通 1.5 小时/断 0.5 小时 70°C ± 2°C, 1000h, Rated voltage 1.5h on/0.5h off
上限类别温度耐久性 Endurance at upper temperature	无可见损伤 No mechanical damage $\Delta R \leq \pm (3.0\%R + 0.005 \Omega)$	125°C ± 2°C 1000h
耐溶剂性 Resistance to Solvent	无可见损伤 No mechanical damage $\Delta R \leq \pm (1.0\%R + 0.005 \Omega)$	浸入三氯乙烯 10h ± 1h Dip in chloroethylene for 10h ± 1h.
绝缘电阻 Insulation Resistance	1000MΩ Min	在电极与基片间施加 100V 直流电压, 保持 1 分钟, 然后测绝缘电阻值。 Apply DC 100V between substrate and termination for 1 minute, then check insulation resistance.
耐焊接热 Resistance to Soldering Heat	无可见损伤 No mechanical damage $\Delta R \leq \pm (1.0\%R + 0.005 \Omega)$	260°C ± 5°C 10s ± 1s
可焊性 Solderability	可焊面积 ≥ 95% 95% Cover Min	235°C ± 5°C 2s ± 0.5s
附着力 Adhesion	外观无可见损伤 No mechanical damage	施加力 5N 10s ± 1s Applying 5N 10s ± 1s

■ 包装 Packaging

● 编带包装 Tape and reel

- * 纸带编带 Paper taping
0603、0805、1206、1210:

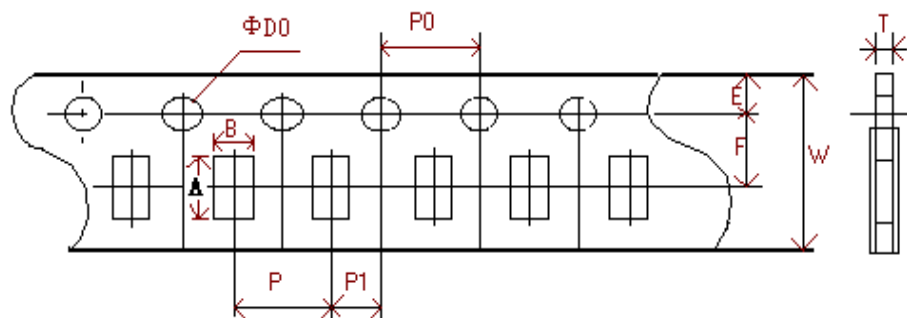

单位 unit: mm

型号 Type	A	B	W	F	E
0603	1.85 ± 0.1	1.10 ± 0.1	8.0 ± 0.20	3.5 ± 0.05	1.75 ± 0.1
0805	2.35 ± 0.1	1.65 ± 0.1	8.0 ± 0.20	3.5 ± 0.05	1.75 ± 0.1
1206	3.50 ± 0.2	1.90 ± 0.2	8.0 ± 0.20	3.5 ± 0.05	1.75 ± 0.1
1210	3.50 ± 0.2	2.80 ± 0.2	8.0 ± 0.20	3.5 ± 0.05	1.75 ± 0.1



单位 uni t: mm

型号 Type	P	P0	P1	D0	T
0603	4.0±0.1	4.0±0.1	2.0±0.05	1.5±0.1	0.60±0.1
0805	4.0±0.1	4.0±0.1	2.0±0.05	1.5±0.1	0.75±0.1
1206	4.0±0.1	4.0±0.1	2.0±0.05	1.5±0.1	0.75±0.1
1210	4.0±0.1	4.0±0.1	2.0±0.05	1.5±0.1	0.75±0.1

* 塑料带编带 Embossed tapping

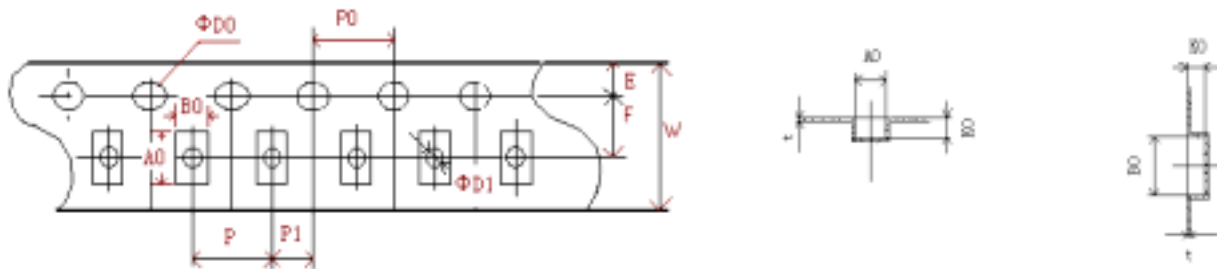

单位 uni t: mm

型号 Type	A0	B0	W	F	E	t
1812	4.80±0.10	3.40±0.10	12.00±0.10	5.50±0.10	1.75±0.10	0.25±0.05
2010	5.45±0.10	2.77±0.10	12.00±0.10	5.50±0.10	1.75±0.10	0.24±0.05
2512	6.73±0.10	3.40±0.10	12.00±0.10	5.50±0.10	1.75±0.10	0.24±0.05

单位 uni t: mm

型号 Type	P	P0	P1	D0	D1	K0
1812	4.00±0.10	4.00±0.10	2.00±0.05	1.55±0.10	1.50±0.10	1.00±0.10
2010	4.00±0.10	4.00±0.10	2.00±0.05	1.50±0.10/-0	1.50±0.10	0.84±0.10
2512	4.00±0.10	4.00±0.10	2.00±0.05	1.50±0.10/-0	1.50±0.10	0.81±0.10

* 卷盘 Reel

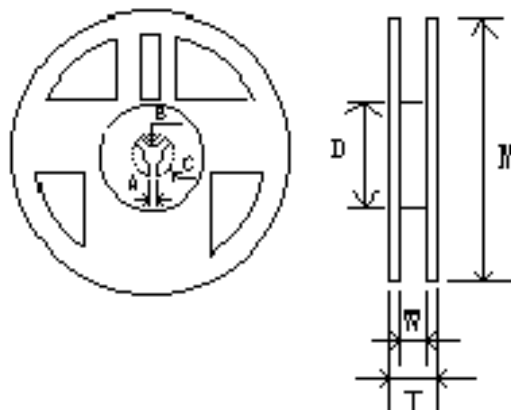



单位 unit: mm

型号 Type	M	W	T	A	B	C	D
0603	178	9.5	12.5	2.0	13.0	21.0	58.0
0805							
1206	±2.0	±1.0	±1.5	±0.5	±0.5	±0.5	±2.0
1210							
1812	178	13.0	15.5	2.0	13.0	21.0	57.0
2010							
2512	±2.0	±0.5	±1.5	±0.5	±0.5	±0.5	±2.0

● 塑料盒包装 Bulk case

单位 unit: mm

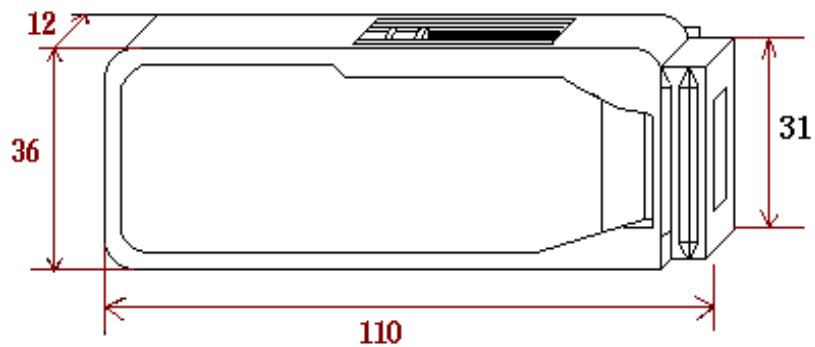

● 包装数量 Packaging quantity

包装方法 Packaging style	编带 Tape and reel		塑料盒 Bulk case					塑料袋散装 Bulk	
	型号 Type	0603 0805 1206 1210	1812 2010 2512	0603	0805	1206	1210 2010	1812 2512	0603 0805 1206
数量 (PCS) Quantity	5000	4000	25000	10000	5000	1500	1000	≤10000	≤4000